

# ZNSE SCANNING LENSES

## 48TSL Series

### Description

The 48TSL scanning lenses are specially designed and optimised for use in CO<sub>2</sub> laser 2-axis galvo-scanner systems with full beam diameters up to 15mm. These single-element lenses are designed to give the best achievable compromise for on-axis and off-axis aberrations over the scanned field and for the mirror arrangements typical of the beam size. The lenses are polished with 1/40<sup>th</sup> wave spherical accuracy and surface roughness is better than 2nm RMS. They provide the smallest possible spot diameter for a single element, see table 10.123

For scanning lenses of other diameters, focal lengths etc, please get in contact by phone or email, giving details of your laser beam, scan head and field size.

### Technical Specifications

- Material:** Lasergrade ZnSe
- Lens type:** Meniscus
- Diameter:** 48.0mm +0/-0.1mm
- Edge Thickness:** 3.0mm ± 0.1mm
- Focal Length:** Within 1%
- Beam Diameter:** <15mm (12mm 1/e<sup>2</sup>)
- Absorption:** ~0.12%
- CW LIDT:** 3000W/mm
- Coating:** AR/AR 10.6µm or 9.3/9.6µm
- Reflectance:** R < 0.2%

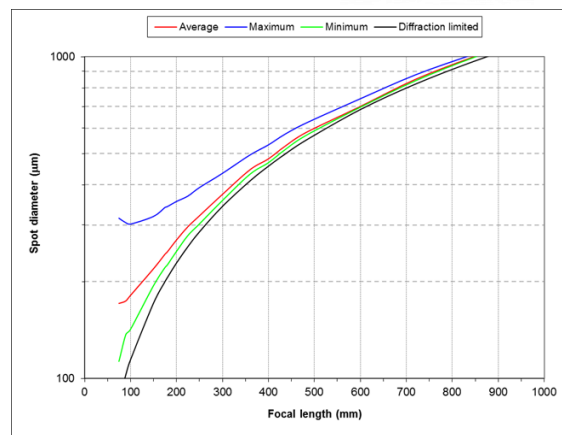

Fig 10.121

The graph of spot size against 48TSL focal length, showing the maximum and minimum values over the field. This graph allows you to compare with the diffraction limit and decide whether it is worth upgrading to a multi-element scanning lens for better performance at the shorter focal lengths.

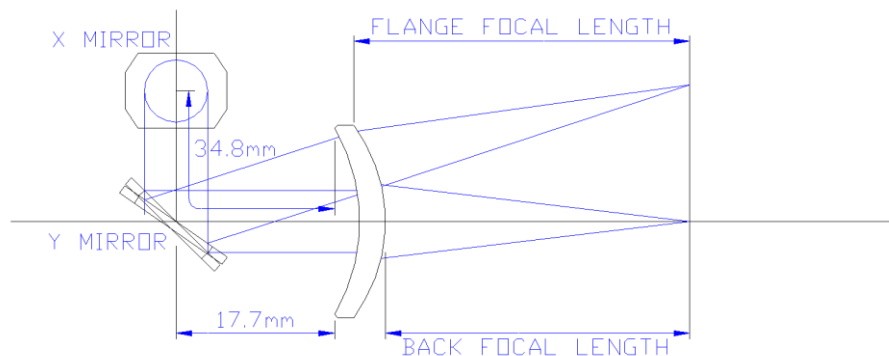

Fig 10.122

The mirror locations are the same for every TSL lens, so any lens can replace any other in the cell and be correctly positioned. The field sizes given assume an optical field angle of ± 20deg.

Table 10.123					
Part no.	Focal length (mm)	Field size (mm)	Back focal length (mm)	Flange focal length (mm)	Average spot diameter (mm)
48TSL75	75.2	50 x 50	74.2	78.4	171
48TSL90	90.1	60 x 60	90.0	94.8	174
48TSL100	101.3	70 x 70	101.4	106.1	181
48TSL150	149.1	105 x 105	150.6	155.6	219
48TSL175	175.0	120 x 120	177.4	178.4	243
48TSL180	179.2	125 x 125	181.9	187.3	247
48TSL200	200.6	140 x 140	203.5	208.8	269
48TSL225	225.5	155 x 155	228.0	232.8	296
48TSL250	249.4	175 x 175	253.3	258.5	320
48TSL300	298.0	210 x 210	302.6	307.7	373
48TSL360	362.6	250 x 250	368.2	373.2	445
48TSL400	394.4	280 x 280	401.4	406.7	481
48TSL435	432.7	300 x 300	441.0	446.2	525
48TSL482	481.8	340 x 340	490.2	495.3	581
48TSL529	529.0	370 x 370	541.4	546.4	606
48TSL600	600.0	415 x 415	611.7	616.4	684
48TSL720	716.5	500 x 500	730.0	734.7	850
48TSL782	782.0	550 x 550	796.6	801.1	888
48TSL848	848.4	600 x 600	859.6	863.7	1000
48TSL977	977.6	680 x 680	993.7	997.9	1150
48TSL1150	1183.0	840 x 840	1205.0	1208.0	1390
49TSL1200	1201.0	850 x 850	1216.0	1220.0	1410
48TSL1285	1285.0	920 x 920	1317.0	1321.0	1520
48TSL1409	1409.0	1000 x 1000	1421.0	1425.0	1650
48TSL1577	1577.0	1120 x 1120	1593.0	1596.0	1840
48TSL1746	1746.0	1256 x 1256	1783.0	1787.0	2040
48TSL2122	2122.0	1500 x 1500	2173.0	2177.0	2420

**Assumptions**

- 1) Focused spot diameters assume 15mm full beam diameter (Approximately 12mm  $1/e^2$ ) and TEM<sub>00</sub> mode ( $M^2 = 1$ ). The 'average' is the mean of 25 field positions in a quadrant.
- 2) Each scanning mirror deflects the beam up to 20degrees from the central position
- 3) See the figure above for the definition of the back focal length and flange focal length. Note that the distances from the edge of the lens are more useful because this is where the mount ledges are located.

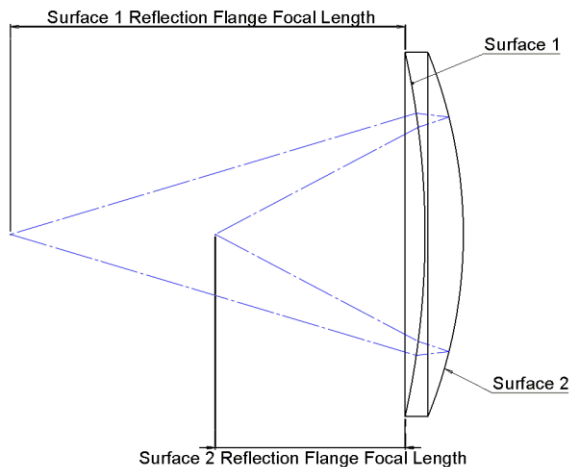

**Fig 10.125**

**Back Reflections**

All lenses come with anti-reflection coating which reduces their reflectance to less than 0.2%. In some very sensitive systems its useful to know the focal length of said 0.2% of reflections to protect mirrors and any previous optics.

Table 10.124		
Part no.	Surface 1 Reflection Flange Focal Length (mm)	Surface 2 Reflection Flange Focal Length (mm)
48TSL75	96.7	13.0
48TSL90	55.9	12.8
48TSL100	52.9	14.2
48TSL150	36.4	15.9
48TSL175	31.1	15.6
48TSL180	30.8	15.7
48TSL200	30.8	16.8
48TSL225	33.0	18.8
48TSL250	29.0	17.7
48TSL300	29.0	19.1
48TSL360	28.4	20.0
48TSL400	26.5	19.4
48TSL435	26.2	19.7
48TSL482	27.2	20.9
48TSL529	28.1	21.8
48TSL600	33.5	23.2
48TSL720	29.0	24.0
48TSL782	30.8	25.6
48TSL848	33.9	28.3
48TSL977	33.0	28.2
48TSL1150	34.4	30.0
49TSL1200	34.4	30.1
48TSL1285	34.4	29.9
48TSL1409	37.4	33.0
48TSL1577	38.4	34.2
48TSL1746	35.5	32.1
48TSL2122	42.5	38.2