

F - T H E T A L E N S

f-170-30-1030-1080-M112

en | Data sheet | 1.1

- Fused silica lens, 1030 – 1080 nm
- Nominal focal length 170 mm
- Max. input beam diameter 30 mm
- Maximum working area 70 x 70 mm
- Very fine focus, high power density



Wavelength	1030 – 1080 nm	Minimum spot size	11.03 μ m
Nominal focal length	170 mm	Mirror distance m1/m2	37.12 / 21 mm
Effective focal length	170.000 mm	Anti-reflective coating	Standard
Flange focal length	319.727 mm	Cooling method	Air
Max. input beam diameter	30 mm	Lens material	Fused silica
Working distance	213.643 mm	Mounting thread	M112x1
Max. scan field	70 x 70 mm	Lens diameter	146 mm

Information is subject to change without notice.
Product photos are non-binding and may show customized features.



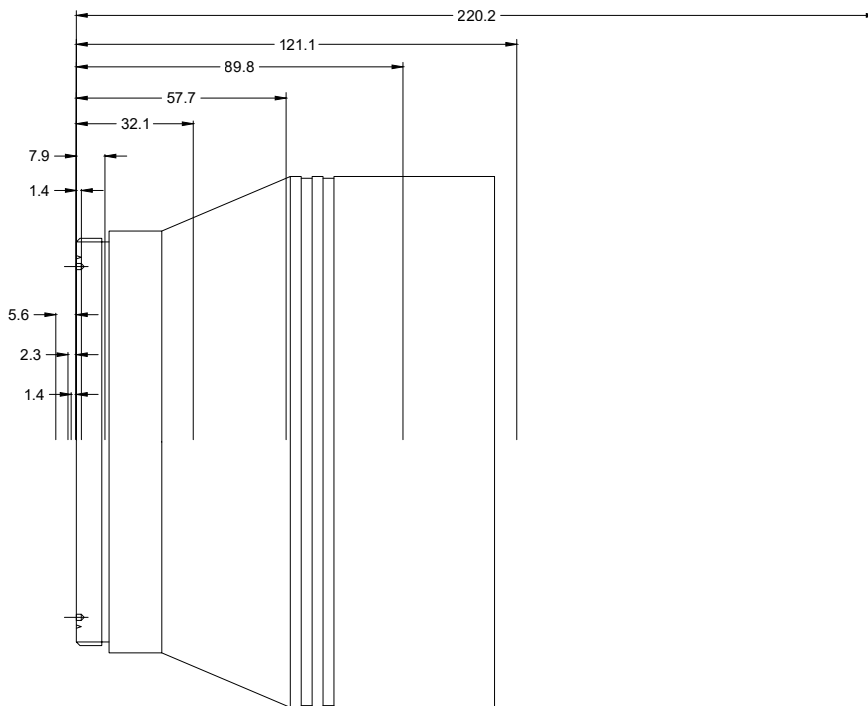
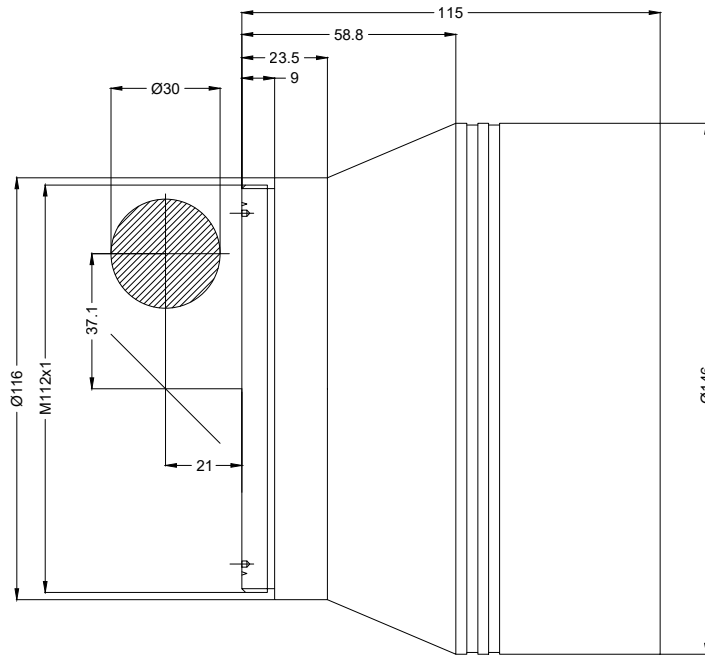

F-Theta lens

f-170-30-1030-1080-M112

Dimensions are given in millimeters and are intended as reference values.
Binding information is available on request.

