

F - T H E T A L E N S

f-420-30-1030-1080-M102

en | Data sheet | 1.1

- Fused silica lens, 1030 – 1080 nm
- Nominal focal length 420 mm
- Max. input beam diameter 30 mm
- Maximum working area 200 x 200 mm
- Very fine focus, high power density



Wavelength	1030 – 1080 nm	Minimum spot size	27.53 μm
Nominal focal length	420 mm	Mirror distance m1/m2	37.12 / 24 mm
Effective focal length	425.450 mm	Anti-reflective coating	Standard
Flange focal length	620.935 mm	Cooling method	Air
Max. input beam diameter	30 mm	Lens material	Fused silica
Working distance	533.435 mm	Mounting thread	M102x1
Max. scan field	200 x 200 mm	Lens diameter	146 mm

Information is subject to change without notice.
Product photos are non-binding and may show customized features.



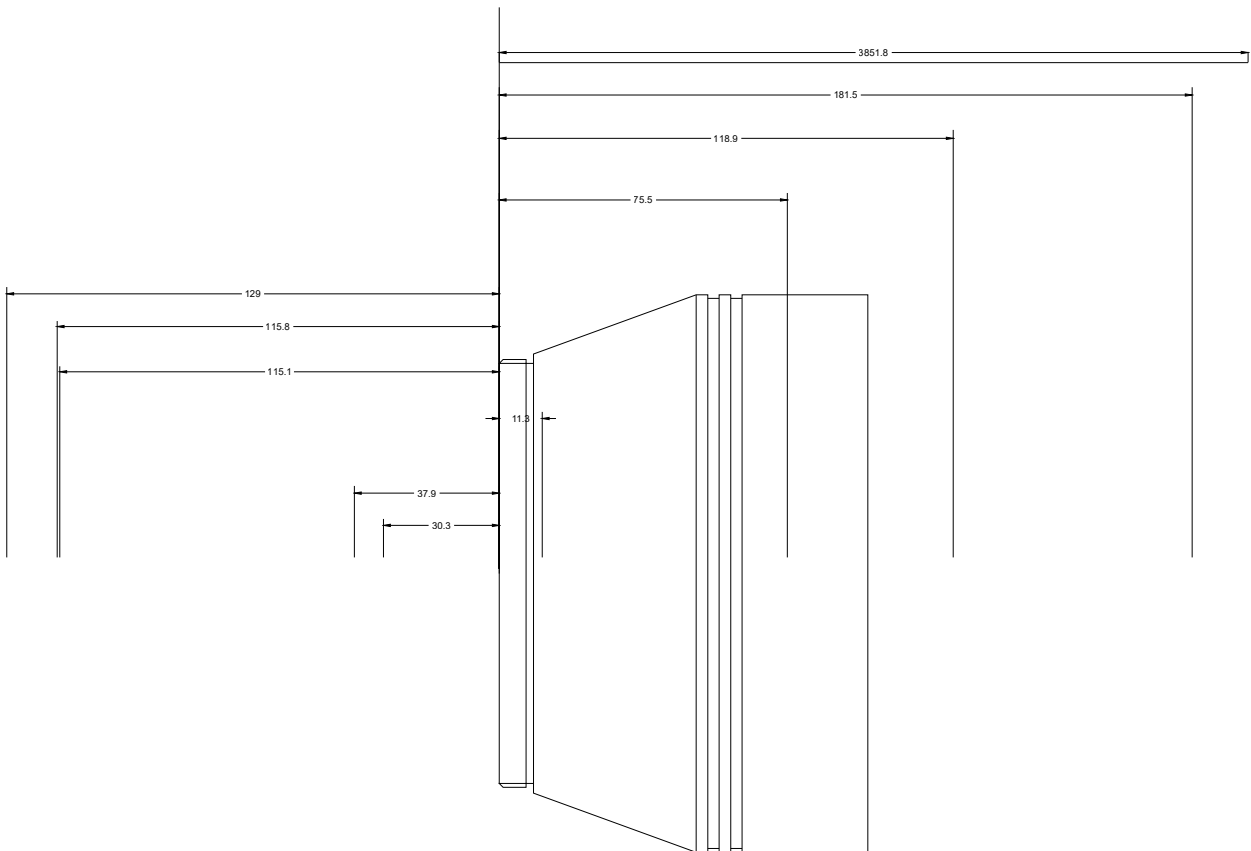
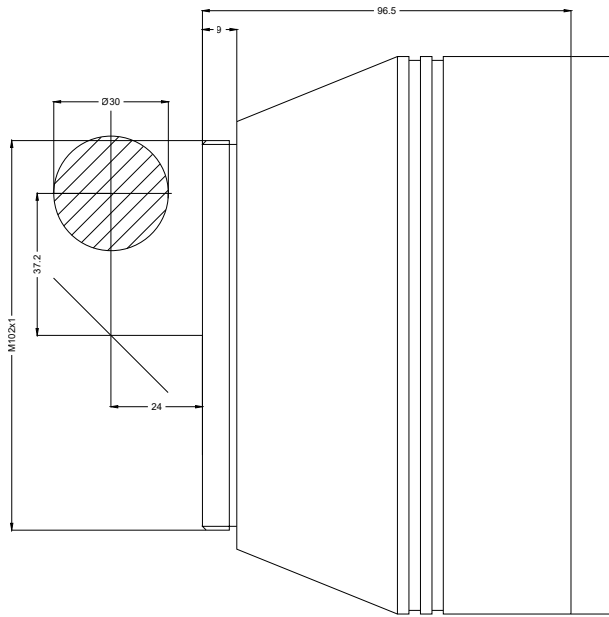

F-Theta lens

f-420-30-1030-1080-M102

Dimensions are given in millimeters and are intended as reference values.
Binding information is available on request.

