

F - T H E T A L E N S

# f-100G-10-532

en | Data sheet | 1.1

- F-Theta Focusing Lens, 532 nm
- Nominal focal length 100 mm
- Max. input beam diameter 10 mm
- Maximum working area 60 x 60 mm



Wavelength	532 nm	Minimum spot size	9.74 $\mu$ m
Nominal focal length	100 mm	Mirror distance m1/m2	12.5 / 15 mm
Effective focal length	100.000 mm	Anti-reflective coating	Standard
Flange focal length	120.874 mm	Cooling method	Air
Max. input beam diameter	10 mm	Lens material	Optical glass
Working distance	112.774 mm	Mounting thread	M85x1
Max. scan field	60 x 60 mm	Lens diameter	90 mm

Information is subject to change without notice.  
Product photos are non-binding and may show customized features.



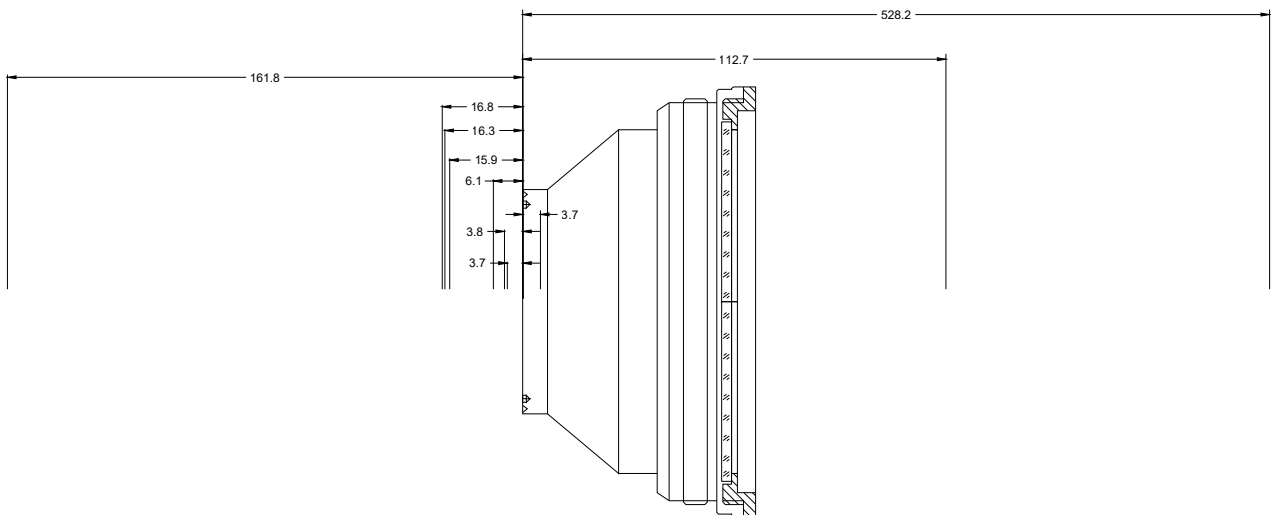
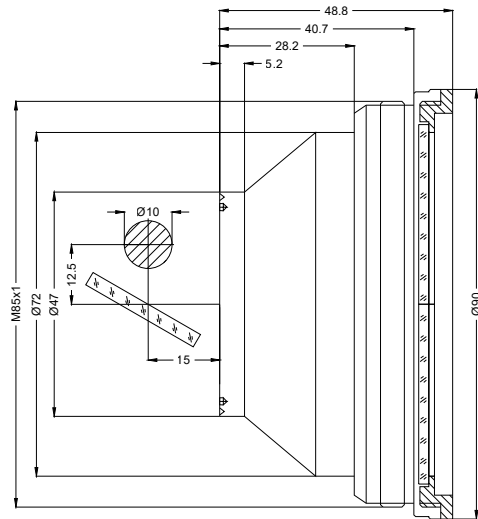

F-Theta lens

f-100G-10-532

Dimensions are given in millimeters and are intended as reference values.  
Binding information is available on request.

