

C W F I B E R L A S E R

# CW-2000SM-L-PLD

en | Data sheet | 1.0

- Ideal for Additive Manufacturing, Laser Cutting and Welding
- Excellent power stability and optical characteristics
- High safety standard due to Performance Level D



Wavelength	1080 nm	Cooling method	Water
Nominal output power (CW)	2050 W	Cooling flowrate	15 l/min
Laser operation mode	CW, modulated	Cooling power	6 kW
Beam parameter product (BPP)	0.45 mm*mrad <sup>[1]</sup>	Aiming beam	Standard
Fiber core diameter	14 µm <sup>[2]</sup>	Output type	QBH
Modulation frequency	1 – 20 Hz	Supply voltage AC	220 V
Power instability Ø	2%	Current consumption	27.27 A
Power tuning range	10 – 100%	Power consumption @ 20°C	6000 W
Polarization	Random	Operation temperature	10 – 40 °C
Fiber length	10 m <sup>[3]</sup>	Storage temperature	-20 – 50 °C
		Mechanical dimensions (W × D × H)	482 × 571 × 135 mm
		Net weight	36 kg

Product customizations are possible on request.

<sup>[1]</sup> Depending on fiber core diameter

<sup>[2]</sup> Other available fiber core diameters: 20 µm / 25 µm

<sup>[3]</sup> Other available fiber lengths: 15 m / 20 m



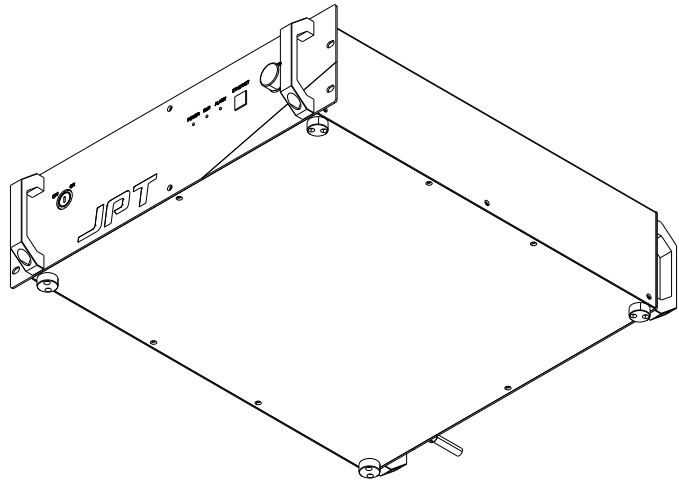
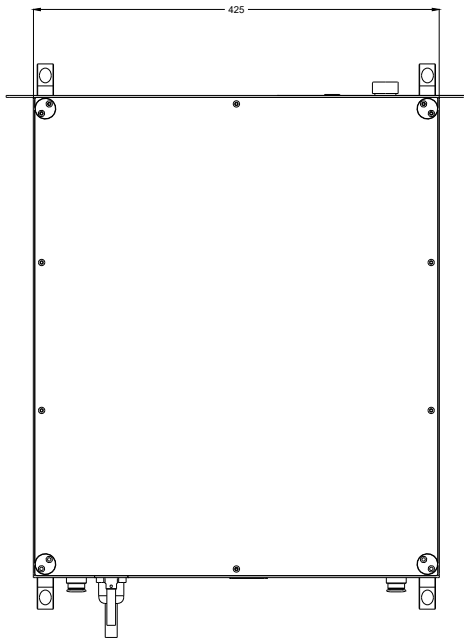
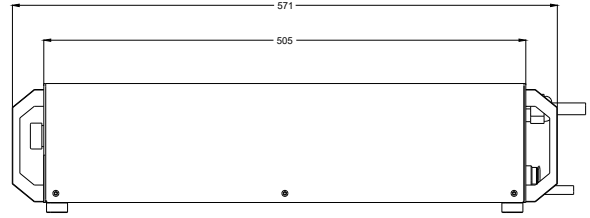
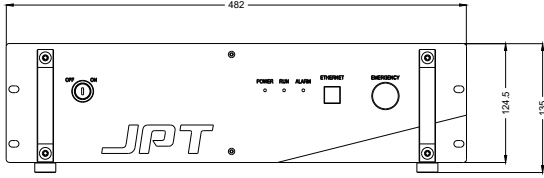

Laser product  
Class 4

## JPT

Manufacturer

CW fiber laser

CW-2000SM-L-PLD

Dimensions are given in millimeters and are intended as reference values.  
Binding information is available on request.

