

2 D SCAN HEAD

BS-30

en | Data sheet | 1.1.1

- 2-axis laser deflection unit, aperture 30 mm
- Laser power up to 3000 Watt, CW 1064 nm
- High precision for industrial use
- Outstanding cost-effectiveness



Wavelength	1064 nm ^[1]	Long-term-drift per axis (8 h)	300 µrad
Input beam diameter	30 mm	Cooling method	Passive
Tracking delay	0.5 ms	Control interface	XY2-100-Standard
Writing speed	220 cps	Humidity	80% ^[2]
Max. optical deflection	0.393 rad	Supply voltage DC	15 V
Resolution	12 µrad	Current consumption	5 A
Repeatability (RMS)	22 µrad	Operation temperature	10 – 40 °C
Positioning noise (RMS)	4.5 µrad	Storage temperature	-20 – 60 °C
Max. gain-drift per axis	50 ppm/K	Mechanical dimensions (W × D × H)	158 × 198 × 160 mm
Max. offset-drift per axis	30 µrad/K	Net weight	5 kg

^[1] Other available wavelengths: 355 / 450 / 532 / 10600 nm

^[2] Non condensing



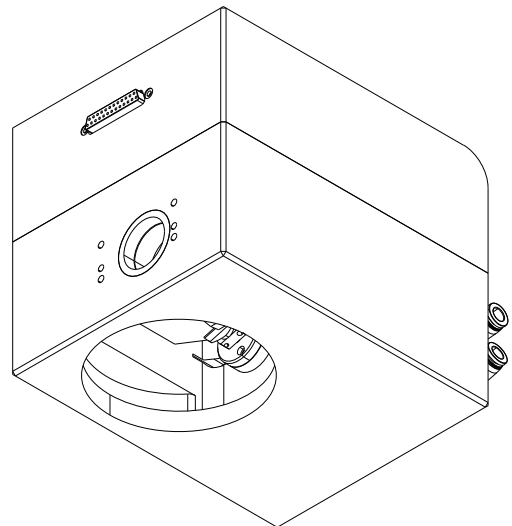
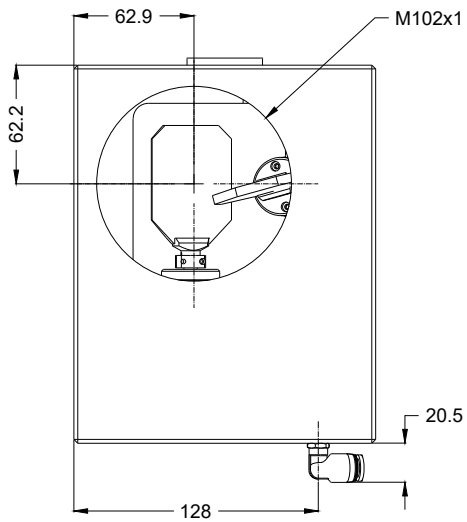
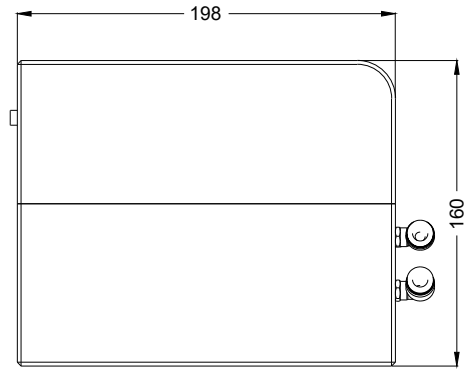
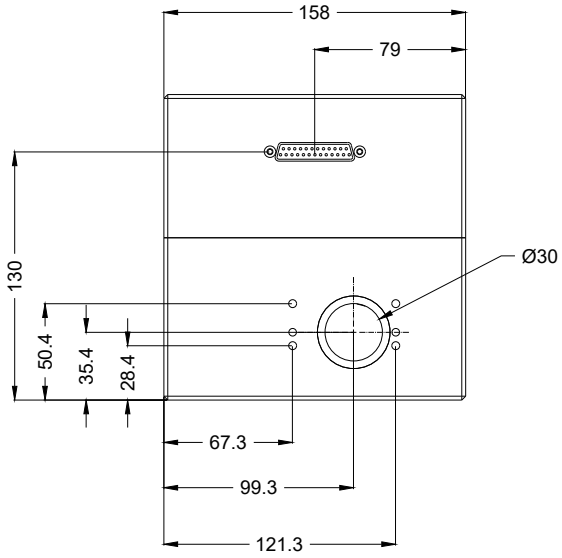

2D scan head

BS-30

Dimensions are given in millimeters and are intended as reference values.
Binding information is available on request.

